

CONTENTS

ANNALS OF

IMPROBABLE RESEARCH



The features marked with a star () are based entirely on material taken straight from standard research (and other Official and Therefore Always Correct) literature. Many of the other articles are genuine, too, but we don't know which ones.*



SPECIAL SECTION: THE 2013 IG NOBEL PRIZES

- 6 The 23rd First Annual Ig Nobel Prize Ceremony * — *Stephen Drew*
- 10 The 2013 Ig Nobel Prize Winners*
- 14 The Acceptance Speeches*
- 18 The 24-7 Lectures*
- 19 LIBRETTO: The Blonsky Device — *Marc Abrahams*



IMPROBABLE RESEARCH REVIEWS*

- 4 Improbable Research Review* — *Dirk Manley*
- 5 Improbable Medical Review* — *Bertha Vanatian*

NEWS & NOTES

- IFC KIM CARTOON: “Detectives Who Are Fish” — *Nick Kim*
- 2 AIR Vents (letters from our readers)
- 3 Editorial Board
- 26 Ig® Nobel Limericks: Beetles, Cows, Intoxication* — *Martin Eiger*
- 26 Teachers' Guide
- 27 Subscriptions and eBooks for You and Your Colleagues
- 28 Puzzling Solutions — *Emil Filterbag*
- 28 Index of Special Issues
- IBC Unclassified Ads



On the Front Cover

The Ig Nobel Medicine Prize winners deliver their acceptance speech in song. Photo: Mike Benveniste.



On the Back Cover

Minordomos (left to right) Chris Deter, Alex Nemiroski, John Armstrong, Eliza Kosoy, Sylvia Rosenberg, and Ben Biggs demonstrate a novel method of performing single-handed applause. Photo: David Holzman.

Some Coming Events

See WWW.IMPROBABLE.COM for details of these and other events:

- January 2014 ARISIA, Boston, MA, USA
- February 2014 AAAS Annual Meeting, Chicago, IL, USA
- March 2014 Ig Nobel events in Scandinavia, UK, Ireland
- April 2014 Washington, DC, USA
- June 2014 ESOF, Copenhagen, Denmark

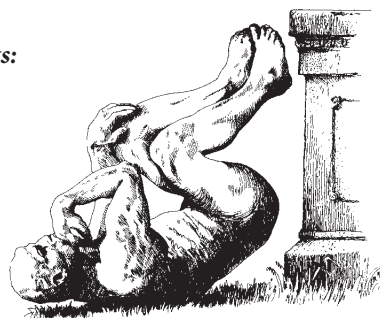

EVERY DAY

Read something new and improbable every day on the Improbable Research blog, on our web site:

WWW.IMPROBABLE.COM

LIBRETTO: THE BLONSKY DEVICE

Words: Marc Abrahams

Music: Charles-François Gounod, Ludwig van Beethoven, and Gioachino Antonio Rossini

Orchestration: Henry Akona

(Thanks to Dr. Thomas Michel for musical and medical consultations.)

The Blonsky Device premiered as part of the 23rd First Annual Ig Nobel Prize Ceremony, at Sanders Theater, Harvard University, Cambridge, Massachusetts, on September 12, 2013. Video of the performance can be seen at www.improbable.com/ig/2013/.

Original Cast

Director, conductor, and arranger: Henry Akona

Assistant director: Chelsea Long

Charlotte Blonsky: Maria Ferrante, soprano

George Blonsky: Martin Kelly, tenor

The Zookeeper: Philip Lima, baritone

The Patent Examiner: Miles Rind, bass

Narrator: Karen Hopkin

Blonsky device mechanics: Melissa Franklin, Peaco Todd, Alex Nemiroski

Other scientists, doctors, and engineers: Nobel laureates Dudley Herschbach, Roy Glauber, Eric Maskin, and Frank Wilczek, and all the 2013 Ig Nobel Prize winners, past winners, and 24/7 Lecturers.

With an all-star biomedical orchestra, “The Forces of Nature,” composed of Harvard and MIT physicians and researchers:

- *Accordion:* Thomas Michel (Harvard Medical School Professor of Medicine)
- *Violin:* Ted Sharpe (computational biologist at the Broad Institute)
- *Cello:* David Fisher (Harvard Medical School Professor and Chair of Dermatology)
- *Flute:* Elizabeth Henske (HMS Professor of Medicine)
- *Bassoon:* Ben Steinhorn (HMS MD-PhD student)
- *Clarinet:* Abby Schiff (HMS MD-PhD student)
- *Trombone:* Chris Ramirez (Harvard College undergrad)
- *Percussion:* David Gootenberg (HMS MD-PhD student)

Costumes: Catherine Quick Spingler

Props: Eric Workman

ACT 1— Sunday at the Zoo with George and Charlotte

NARRATOR: This is the story of a married couple named George and Charlotte Blonsky. The Blonskys invented a machine. They called it “an apparatus for facilitating the birth of a child by centrifugal force.” In the year 1965, the Patent Office granted them a patent—patent number 1126423. In the year 1999, George and Charlotte were posthumously awarded an Ig Nobel Prize for their invention. This is the story—with a few extra touches, we admit!—of how the Blonskys got their idea, and of how they MIGHT have used the machine. It all began with a visit to the zoo...

[MUSIC: Gounod’s “Funeral March of a Marionette”]

BOTH: What shall we do? Go to the zoo! Ooh. Ooh.

BOTH: Let’s go to the zoo today!

Let’s go to the zoo today!

CHAR: The elephants! The elephants! The elephants!

Let’s go see them! Let’s go!

BOTH: Let’s go to the zoo today!

[THEY HAVE OPPOSITE OPINIONS ABOUT WHERE THE ELEPHANTS ARE. HOLDING HANDS, EACH TRIES TO PULL THE OTHER IN THE PROPER DIRECTION. THIS RESULTS IN THE PAIR OF THEM SLOWLY ROTATING.]

CHAR: El-e-phants! Let’s see the wonders of nature—the physics and engineering!

GEO: Let’s study the elephants’ well-controlled, en-dear-ing power steering.

GEO: Let’s go see a pachyderm! Let’s go!

CHAR: Oh, that’s such a tacky term, you know!

GEO: No, no! Right over there!



Director/conductor/arranger Henry Akona and the all-star biomedical orchestra, “The Forces of Nature.” Photo: Mike Benveniste.

CHAR: No! Right over there!
 [CHAR IS BEING VERY PLAYFUL]
 GEO: You're turning me, turning me all around!
 You're making me gasp and blink!
 CHAR: Rotation might make you THINK!
 Spinning, spinning, spinning while dancing—I think can be quite entrancing!
 Thoughtful, pondering people like to spin!
 GEO: Spinning, spinning, spinning, spinning.
 [GEO ALSO BECOMES PLAYFUL]
 GEO: SOME people think spinning is a sin!
 CHAR: Sin! They don't understand how usefully grand some ev'ryday actions can be.
 A sin! A sin! A sin! Sin!
 CHAR: Hey, elephants—they have sense!
 CHAR: El-e-phants!
 GEO: Their wisdom can be immense!
 CHAR: So maybe we would be dense not to study the elephants.
 GEO: Oh, elephants have sense. Elephants!
 [THEY SEE AN ELEPHANT. THE ELEPHANT IS SLOWLY SPINNING. GEORGE AND CHARLOTTE ARE ENTRANCED AND EXCITED AND MYSTIFIED]

CHAR: That elephant over there—the one that's spinning round and round—but WHY?
 CHAR and GEO: That elephant over there is quite astounding, quite confounding!
 That elephant over there—good gosh! Good glory! What's the story?
 [THE ZOOKEEPER ENTERS]
 ZOO: Zookeeper here! You can ask me any questions! Folks, I will cheerfully answer all your questions!
 GEO and CHAR: Please tell us, sir, why that elephant is spinning?
 ZOO: Ah, she is pregnant—beginning to give birth!
 CHAR: An elephant giving birth!
 ZOO: That's right.
 CHAR: Well, that would explain her girth!
 ZOO: That's right.
 CHAR: Peculiar! How uncommon! What exactly is the phenomenon?
 GEO: Rotation at constant speed!
 ZOO: That's right.
 GEO: Rotation at constant speed!
 ZOO: That's right.
 GEO: Those rotations have anatomical, int'resting implications!
 ZOO: Pregnant elephants typic'y spin around.
 Yes, pregnant elephants—yes, they go round and round.

GEO and CHAR: Does that force make mom feel kind of quivery?
 ZOO: The force, we think, must aid in the delivery.
 For the baby elephant, force of course is relevant.
 GEO and CHAR: Force is not irrelevant for a baby elephant.
 ALL THREE: Of course you need that force, if you're an elephant. An elephant needs force.
 ALL THREE [PLAYFULLY ACTING AS IF THEY HAVE HUGELY PREGNANT BELLIES]: And so do WE...
 GEO: And so do WE...
 CHAR: And so do WE...
 ZOO: It's a clever use of force, of course.
 CHAR and GEO: The wisdom of elephants!
 ZOO: A use I can endorse, of course.
 CHAR and GEO: The wisdom of elephants!
 CHAR: Strong propelling force to push aside constricting walls that are vaginal!
 GEO and ZOO: To force aside the walls!
 CHAR: Yes, the wisdom of elephants!
 GEO: The wisdom of elephants!
 ZOO: Push aside the mighty walls, yes.
 CHAR: E-le-phants.
 GEO: The wisdom of elephants!
 ZOO: Push aside the mighty walls, yes.
 CHAR: To push those vaginal walls, they rely on centrifugal force!
 GEO: Vaginal walls, push, push!
 ZOO: Push! Push! Push! Push!
 ZOO: Push! Push!
 GEO: Use centrifugal force!
 ZOO: Centrifugal force—
 GEO: Centrifugal force—
 CHAR: Centrifugal force for motherhood!
 ZOO: Centrifugal force—
 GEO: Centrifugal force—
 CHAR: Centrifugal force for motherhood! WE CAN MAKE A MACHINE!
 GEO: Force for mother!
 ZOO: For... mother!
 GEO: A big machine. Help old biddies have kids!
 ZOO: A big one! Hope that no one forbids!
 GEO: We can make a machiiiine!
 ZOO: Machiiiine!



Charlotte and George Blonsky (played by Maria Ferrante and Martin Kelly) and the friendly zookeeper (played by Philip Lima) explore the mechanics of how an elephant gives birth. Photo: David Holzman.



LEFT: The patent examiner (played by Miles Rind) questions George. Photo: David Holzman.
CENTER: The patent examiner prepares to reject the patent application. Photo: Mike Benveniste.
RIGHT: Charlotte's baby suddenly makes its imminent presence known. Photo: Mike Benveniste.

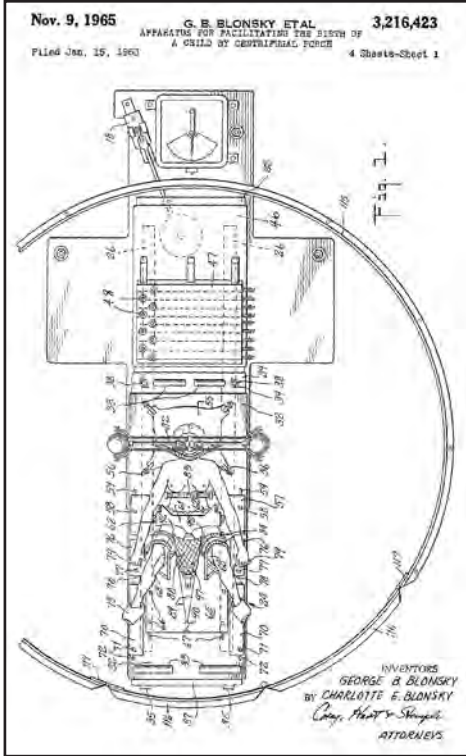

Technical drawing from the Blonsky patent.



Page 1 of the actual Blonsky patent.

PAT: It's goodly sized?!
GEO: The woman lies down on her back.
PAT: She's on a rack?!
GEO: And then you rotate her at sixty R-P-M.
PAT: I must condemn—
GEO: And so the child comes flying out—it's quick and fun!
PAT: I think we're done.
CHAR: It's very simple! It's a simple apparatus for delivery of babies, with a turntable that spins the mother, and ejects the child.

[THEY EXAMINE THE PATENT DRAWINGS—THESE DRAWINGS ARE BIG—THE AUDIENCE CAN SEE AND SAVOR THEM.]

PAT: Clever. Ever... so clever. However. Whatever. Wherever. Whenever. Whoever. Whomever. Errrrrr.
GEO and CHAR: Total safety! No danger! Total safety! No danger!

Many safeguards! Many safeguards! Many safeguards! Many safeguards!
Boxes with ballast water! Boxes with ballast water!
Butt plates! Wing nuts! Steel gates! Deck butts!

PAT: Fascinating. Fascinating. Fascinating. Fascinating. Fa-ci-na-ting.

GEO and CHAR: Precise rotation... will cause cessation... of the gestation.
GEO and CHAR: Yes! Oh yes, it will.

[CHARLOTTE AND GEORGE ARE GROWING PANICKY, AND START TO BABBLE]

Oh! ...precise rotation... will cause cessation...

Oh! ...will cause cessation... of the gestation...

PAT: Round and round, and / up and down, and / lost and found, and / poor confound- / ed baby.

PAT: Round and round and / up and down and / lost and found and / poor confound- / ed...

GEO: But even still...
PAT: Still...
CHAR: But still...

PAT: But still...
GEO: So full of fear...
CHAR: So full of fear...

PAT: So full of fear...
CHAR and GEO: So full of fear...
A mother is so full of fear.

PAT: Fear... A mother is so full of fear.
GEO and CHAR: So full of fear.

PAT: Fear I must reject, I must reject, I must reject... Must reject, I must reject, I must reject, I must reject...

GEO: Oh, please! Oh, please! Oh, please! Oh, please! Oh, please! Oh!

CHAR: Oh, please! Oh, please! Oh, please! Oh, please! Oh!

[CHARLOTTE BURSTS INTO TEARS]

CHAR: My head is spinning! / It's the beginning! / I think my baby is... / popping out TODAY! HEY!

GEO: My head is spinning! / Is it beginning? / I think our baby is... / popping out TODAY! HEY!

PAT: My head is spinning! / Is it beginning? / Good God, your baby is... / popping out TODAY! HEY!

GEO: HEY! Don't worry, Charlotte Blonsky! Don't worry 'bout the PAT: HEY! Don't worry, Missus CHON!

CHAR: Blonsky! I worry 'bout the CHAR: patent! Now let's move! Oh, babe! Let's move!

GEO: patent! Now let's move! Go, babe! Let's move!

PAT: Patent I APPROVE! Whoa, babe! APPROVE!

ACT 3— Doubts Before Launch

[George and Charlotte are playing with a miniature, rough working model of the machine]

NARRATOR: The hour is approaching when Charlotte will give birth—give birth to the Blonskys’ first child—the first child anywhere, ever, to enter the world propelled by centrifugal force. Now, at the last minute, George and Charlotte are having a debate. George is full of doubts. Charlotte is confident and (mostly) unafraid. Charlotte reminds him, diplomatically and happily, that it is she—not he—who will soon be strapped onto the machine, and rotated at high speed, so she can give birth to a bouncing baby.

[MUSIC: Beethoven’s *pathétique*, (2nd movement)]

GEO: It’s a SIN to make a mother spin!
/ Don’t blend her, / Or distend her /
new, ready to debut, kin.

CHAR: It’s NO sin to make a mother spin—
/ Expect her / To eject her /
next—and quite fully flexed—kin.

GEO: My dear, / I so fear / when I hear
/ your ghoulish cheer!

CHAR: To make me spin / Is not a sin.
/ What makes you grimace makes
me grin!

You really ought to know that my
circulation is a little slow!

GEO: Now, I understand that a mother
must have lots of pluck—

CHAR: You must understand that
sometimes things get stuck!

GEO: Yes, I understand that things get
stuck, that things get stuck, things
get stuck.

CHAR: It’s quite sound to spin ma-ma
around. To whirl her! To twirl her.
Tradition is no bound’ry. So... use
acceleration!

GEO: To ensure no child will be left
behind!

CHAR: Circum-propagation!

GEO: To ensure no child will be left
behind!

CHAR: So no child will be...

GEO: So no child will be left behi-ind.

CHAR: So no child will be left
behi-ind.

*Technical drawing from
the Blonsky patent.*



George and a very pregnant Charlotte share a moment and a thought.

Photo: Mike Benveniste.

GEO: What have we to fear?

CHAR: Fear not! Oh, fear not! Oh, fear
not, my dear!

GEO: I’m an engineer! An engineer!
Yes...

CHAR: Such a nice engineer! Such a
good gadgeteer!

Use some force. Yes, of course!

GEO: I’m a dork! I will apply some
torque.

It hastens the child’s naissance,
much quicker than even a stork can!

CHAR: Yes, of course!

GEO: People complain that the force of
a centrifuge is just a “phony” force,
just an il-lu-si-on. I think they think
too hard. They have con-fu-si-on.

They took a physics course. They
are didactical. I am an engineer. My
thoughts are practical. This kind of
force is just not con-tro-ver-si-al.
Not con-tro-ver-si-al! No. It’s in-
er-ti-al!

CHAR: Yes, of course! Apply the
proper force. Rotate me! Else,
irately, [SMILING, JOKING] I would
have to go get a divorce!

GEO: What?!

CHAR: Separation anxiety? Shouldn’t
we feel some chagrin?

BOTH: Separation anxiety? No! ...

Let’s... begin! What say we go for
a spin!

GEO: What say we go for a spin!

BOTH: Spin! Babe! Spin!

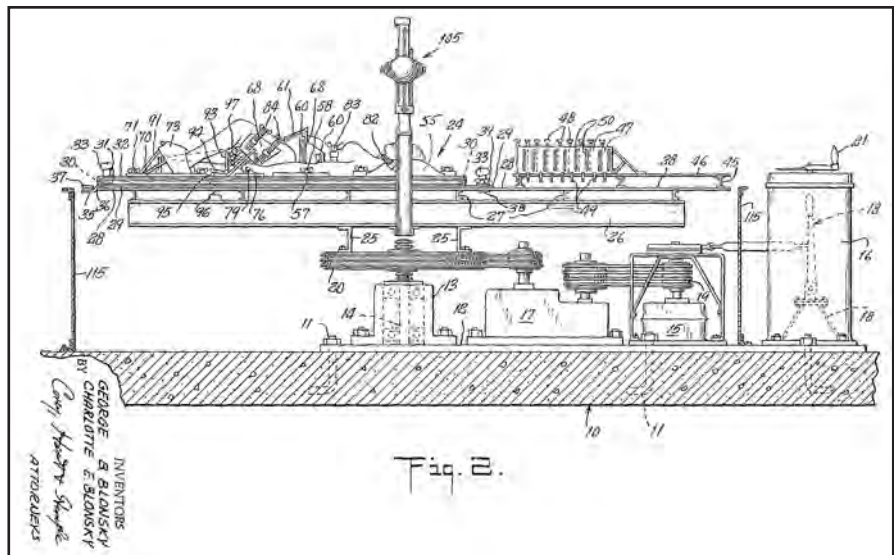



The technicians (Alex Nemiroski with a screwdriver, Peaco Todd with a hammer, Melissa Franklin with a wrench) panic after the Blonsky Device unexpectedly starts up. Photo: David Holzman.

ACT 4—Finale

[WE NEVER SEE THE ACTUAL BLONSKY BIRTHING DEVICE—IT IS OFFSTAGE, OR ALTERNATIVELY, BEHIND A PROTECTIVE CURTAIN. WE DO ALWAYS SEE A LARGE DRAWING, TAKEN FROM THE ACTUAL BLONSKY PATENT, AND DISPLAYED IN THIS ACT MUCH AS IT WAS IN THE PATENT OFFICE SCENE.]

NARRATOR: It's time. It's time for Charlotte to become the first person to give birth... using the Blonsky Device to apply centrifugal force. Their new friends, the Zookeeper and the Patent Examiner, are here, helping them. All their other friends, and many of the world's great scientists, doctors and engineers have gathered to be part of this historic occasion. Around the world, people are watching on live television. [NARRATOR AND ALL THE CAST MEMBERS WAVE AND SMILE INTO THE TV CAMERAS] Now let's join George and Charlotte Blonsky, for the thrilling conclusion to our opera.

[MUSIC: Rossini's "La Gazza Ladra"
[The Thieving Magpie]

GEO: It's about time, my dear!

CHAR: It's about time, my dear! After many, many, many, many months I'm very, very, very, very ready for a change!

GEO: Round about time, my dear!

CHAR: Round about time, my dear!

GEO: Af—ma—, ma—, ma—, ma— months—ve—, ve—, ve—, ve— ready for a change!

CHAR: —ter —ny, —ny, —ny, —ny— I'm —y, —y, —y, —y ready for a change!

GEO: Waiting, and waiting, and waiting uncomfortably!

CHAR: Waiting, and waiting, and waiting uncomfortably!

Anxious and / eager and / no in-be- / tween! I am / bloated and / elephant- / tine! Take me / now! Take me / to the ma- / chine!

GEO: Now, now, now, now, now, now, now.

[GEO and CHAR EXIT]

ZOO and PAT: Such a delightful machine! Such a delightful machine!

Far from routine! Far from routine! Kind of a trampoline!

Such a hygenic machine! Such a hygenic machine!

So very clean... do very clean... seemingly so pristine!

We'd better check each detail. We'd better check each detail.

ZOO: Any detail... any detail... any detail... could fail.

PAT: De-tail... de-tail... de-tail... could fail.

[GEO RE-ENTERS]

GEO, ZOO, PAT:

We'd better check each detail. We'd better check each detail.

GEO: Any detail... any detail... any detail... could fail.

ZOO and PAT: De-tail... de-tail... de-tail... could...

ZOO and PAT: Got to examine it, look at it!

GEO: Look at it carefully! look at it!

ZOO and PAT: Got to examine it, look at it!

GEO: Look at it carefully! look at it!

PAT: Got to examine it, look at it!

GEO: Look at it carefully! look at it!

ZOO: Got to examine it, look at it!

GEO: Got to examine it, look at it!

Carefully look at the anti-friction bearing on the motor shaft.

ZOO: Carefully look at the water-ballast-level gauges, fore and aft.

PAT: Carefully look at the timing mechanism, and the chronograph.

GEO, ZOO, PAT: Take a look at levers listed in the log book!

Take a look at both the safety net and tail hook! Look!

[GEO GOES OFF TO CHECK ON THE MACHINE]

ZOO: Look at the bolts in the holes in the base plate.

Check the alignment. Make sure they are tightened enough.

PAT: Look at the factors affecting the spin rate.

That's your assignment. The ride should be steady, not rough.

ZOO: Check that the bodily orientation's okay!

PAT: Make sure the mother is strapped in to face the right way—

ZOO: Check the direction the mother will lie on the bed!

PAT: Having her backwards is something I dread!

ZOO and PAT: Where are the feet?
[SKIP A BEAT] Where is the head?

[ZOO AND PAT STUDY THE BIG PATENT DRAWING, AND GROW REALLY, REALLY, REALLY WORRIED AND AGITATED AS THEY POINT TO THE PART THAT SHOWS THE NET THAT CATCHES THE CHILD]

[GEO RE-ENTERS]

ZOO: Maybe we should... go slow...

GEO: There's something I should know?

ZOO: Noth—noth—, noth—, noth—, noth—, noth—, noth—, noth—, noth—, noth—, noth—

PAT: —ing, —ing, —ing, —ing, —ing, —ing, —ing, —ing, —ing, —ing, —ing, —ing. Ev'rything is FINE!

PAT: Ev'rything's set to go?

GEO: WHAT IS IT I SHOULD KNOW?!

PAT: Noth— noth—, noth—, noth—,
noth—, noth—, noth—, noth—,
noth—, noth—

ZOO: —ing, —ing, —ing, —ing, —
ing, —ing, —ing, —ing, —ing, —
ing, —ing, —ing.

Ev' rthing is FINE!

ZOO: Well, you see... well, there is one
thing we're wondering about...

GEO: Tell me! You tell me! 'Cause I
need to KNOW what it's about!

Anxious and / eager and / no in-be- /
tween! I am / coated with / stale
nico- / tine! Tell me / now! Tell me
/ 'bout the ma- / chine!

ZOO and PAT: Gosh! Gosh! Gosh!
Gosh! Gosh! Gosh! Gosh!

ZOO and PAT: Such a delightful
machine! Such a delightful
machine!

GEO: Get to the point! Get to the point!
YOU TELL ME WHAT—TELL ME
WHAT DO YOU MEAN?

ZOO and PAT: The tiny NET that
we've seen... That net is far from
routine...

GEO and PAT: That tiny net, that tiny
net—it is the strangest part of the
machine!

GEO, ZOO, PAT: Baby gets caught by
that net. Baby gets caught by that
net.

Look at that net. Look at that net.
Maybe it's adequate. And yet...

Baby relies on that net. Baby relies on
that net.

That net looks frail... That net could
fail!

GEO: That net is something that I
might regret!

ZOO and PAT: That net is something
that he might re—

[THE MACHINE STARTS UP, TO THEIR
SHOCKED SURPRISE]

ZOO and PAT: Somebody started to
spin the machine!!

GEO: Somebody started to spin the
machine!!

ZOO and PAT: Somebody started to
spin the machine!!

GEO: Suddenly, suddenly, suddenly...

ZOO: Whirling and whirling and
whirling and...

PAT: Twirling and twirling and twirling
and...

GEO: Faster and faster and faster and—

GEO, ZOO, PAT: Faster and faster and
faster and—

GEO: No!

ZOO: Oh my gosh! Now the machine is
accelerating! What a twist of fate!

PAT: Go-o-osh! Now my emo-tions are
spinning in a jumbled state!

[OFFSTAGE, CHARLOTTE SCREAMS—A LONG,
RISING SCREAM]

ZOO and PAT: Force keeps her rotating!
She won't keep us waiting!

GEO, ZOO, PAT: Look, here comes the
baby! And I don't mean maybe!

Look, here comes the baby! And I don't
mean maybe!

[THE BABY FLIES IN. THE SCIENTISTS TRY
TO CATCH IT.]

GEO, ZOO, PAT: Ba-by, ba-by, ba-by,
ba-by. Ba-by, ba-by, ba-by, ba-by.
Babe!

PAT: Oot-see bay-bee! Oot-see-coot
bay-bee! Coot-see-oot, oot-see-coot
bay-bee!

GEO, ZOO: Thanks to—

ZOO and PAT: Thanks to— Thanks
to— centrifugal force! Force!
Force! Force!

[CHARLOTTE RE-ENTERS, EXTREMELY DIZZY.
THE CHILD IS PLACED IN HER ARMS.]

CHAR and GEO: Acceleration!
Acceleration! Acceleration!
Acceleration!

ZOO and PC: Force! Force! Force!
Force!

CHAR: Acceleration, oh! Acceleration,
oh! Acceleration, oh! Acceleration,
oh!

GEO, ZOO, PC: Blonsky! Blonsky!
Blonsky! Blonsky!

EVERYONE: Force!

*The patent examiner, the zookeeper,
and Nobel Laureate Dudley
Herschbach, Eric Maskin, Frank
Wilczek, and Roy Glauber welcome
the child. Photo: Alexey Eliseev.*



*The historic first birth of a child using the
Blonsky device. Photos: Mike Benveniste.*



*The real Charlotte and George Blonsky, at
their home in the Bronx. Photo courtesy of
Gale Sturtevant, the Blonskys' niece.*